

# 7919040095 Linde Forklift Joystick

## Product Features

- Dual axis, cross control;
- Mechanical spring-return to center;
- Full sealed design;
- Operation force:  $2N \pm 1N$ ;
- Operation temperature:  $-35^{\circ}$  to  $80^{\circ}$ ;
- Easy to install, flexible operation, uniform texture, maintenance-free;
- 5 million life cycles.

## Application

Fits to the following Linde models:

Linde 1123 R14SP/R16SP/R18SP, Linde 115C-11 R10C/R12C/R14C-11  
 Linde 115-12 R14/14G/16/16G/20/20G-12, Linde 115 R14/R16/R20  
 Linde 115-02 R14/R16/R20-02, Linde 115G-03 R14G-03/R16G-03/R20G-03  
 Linde 115-03 R14/R16/R20-03, Linde 115C-03 R10C/R12C/R14C-03



## Mounting Dimension

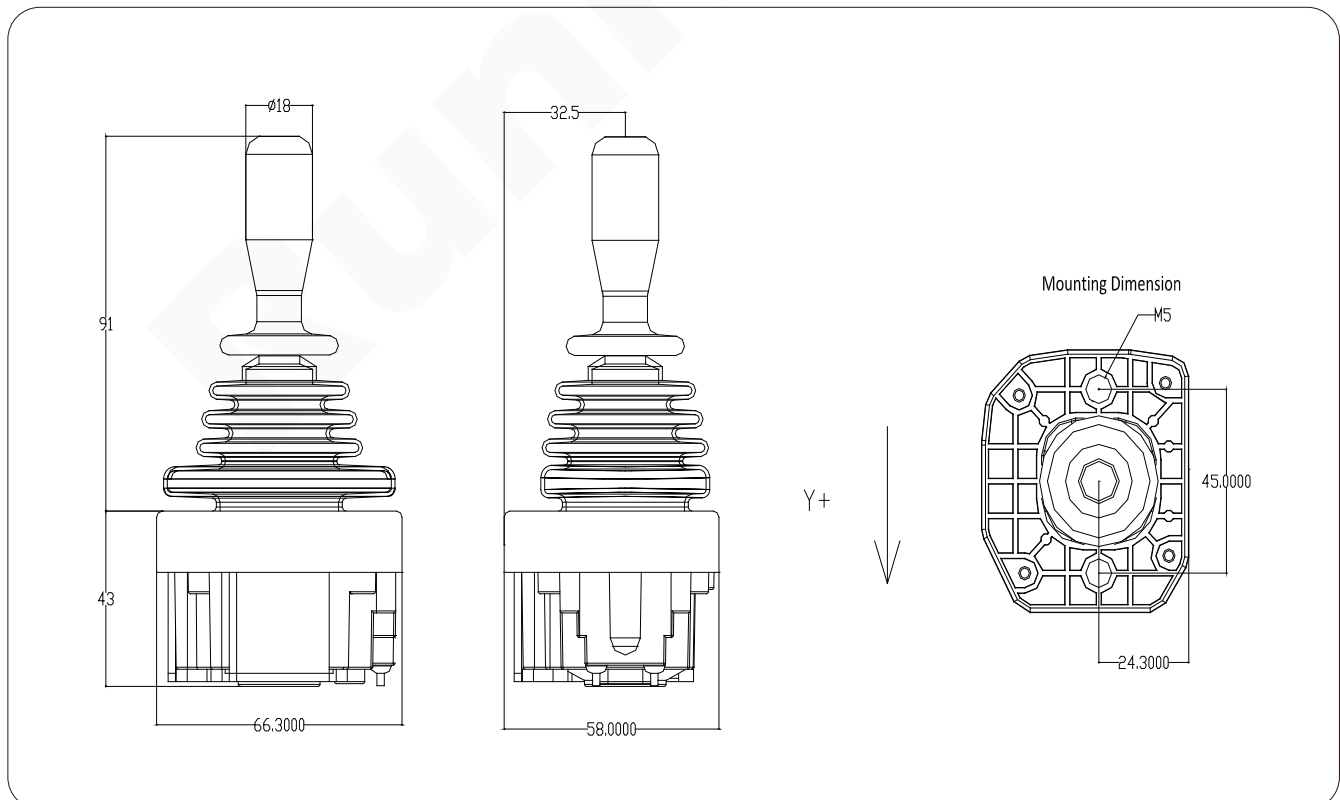

# 7919040093 Linde Forklift Joystick

## Product Features

- Single axis movement;
- Mechanical spring-return to center;
- Full sealed design;
- Operation force:  $2N \pm 1N$ ;
- Operation temperature:  $-35C^{\circ}$  to  $80C^{\circ}$ ;
- Easy to install, flexible operation, uniform texture, maintenance-free;
- 5 million life cycles.

## Application

Fits to the following Linde models:

Linde 1123 R14SP/R16SP/R18SP, Linde 115C-11 R10C/R12C/R14C-11

Linde 115-12 R14/14G/16/16G/20/20G-12, Linde 115 R14/R16/R20

Linde 115-02 R14/R16/R20-02, Linde 115G-03 R14G-03/R16G-03/R20G-03

Linde 115-03 R14/R16/R20-03, Linde 115C-03 R10C/R12C/R14C-03



## Mounting Dimension

